

Thank you for purchasing the www.crafthub.io clip on cockpit kit



For 1/10 scale drift car detail up kit.

This kit is detail up kit for RC drift Car. You can chose RHD/LHD. Connect the servo to receiver's unused channel, and mixing steering channel with your chosen channel. LED power also take from the receiver.

Note

This data is optimized for 1/10 Scale drift Car,

Data kit

You have to print out all parts by yourself. The material you should use depends on the parts. Please chose the correct and affordable material.

Future

- Design for 1/10 scale drift Car.
- You don't need any modification, even make a hole in genuine chassis.
- Real Steering Wheel moves
- Detachable steering Wheel
- 1/10 Scale engine monitors
- Hand break Lever

What is contained in this kit?

Parts list of this kit

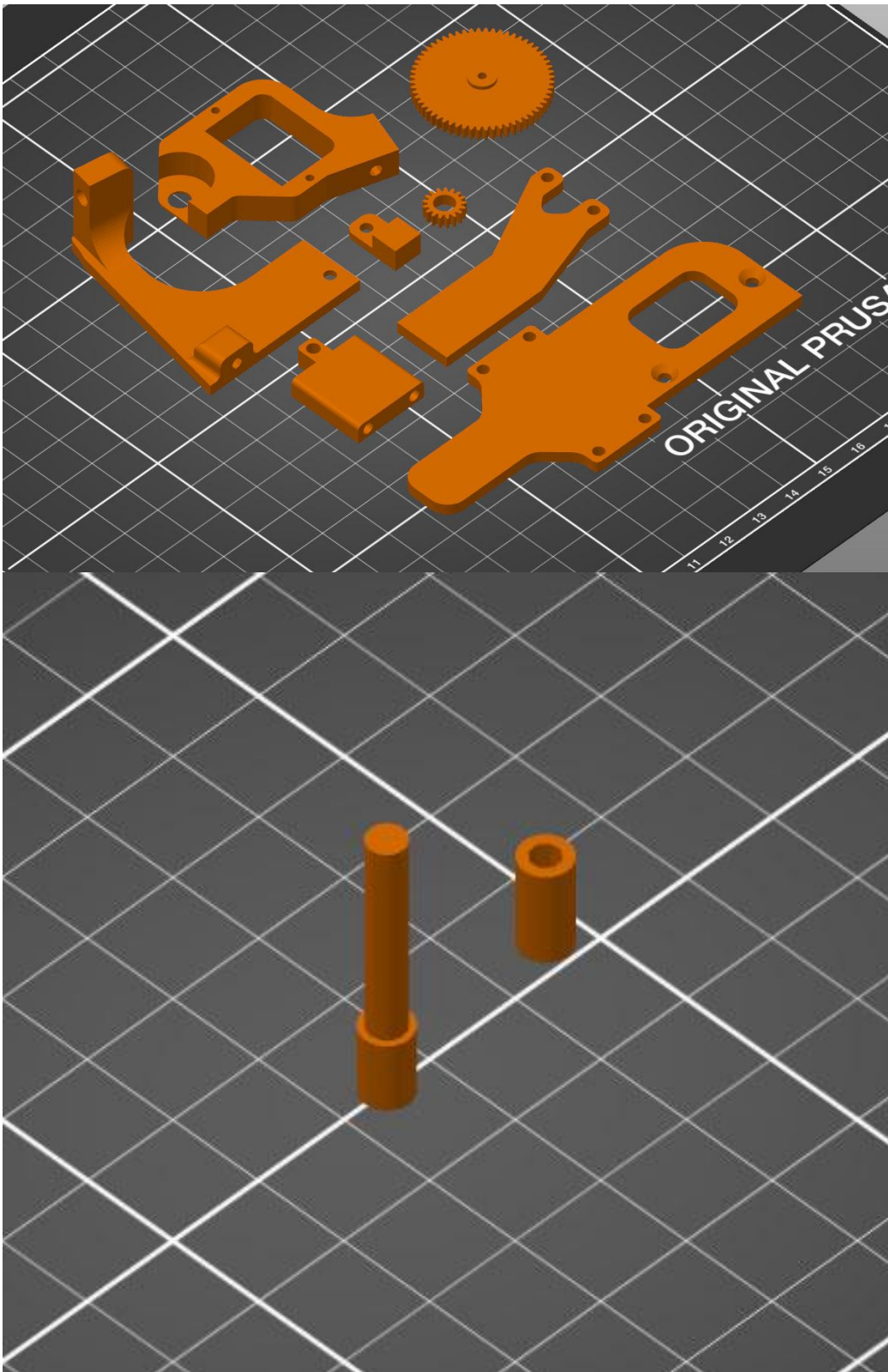

Print with PETG or more tough material. PLA is not recommended,however indoor use can be okay.

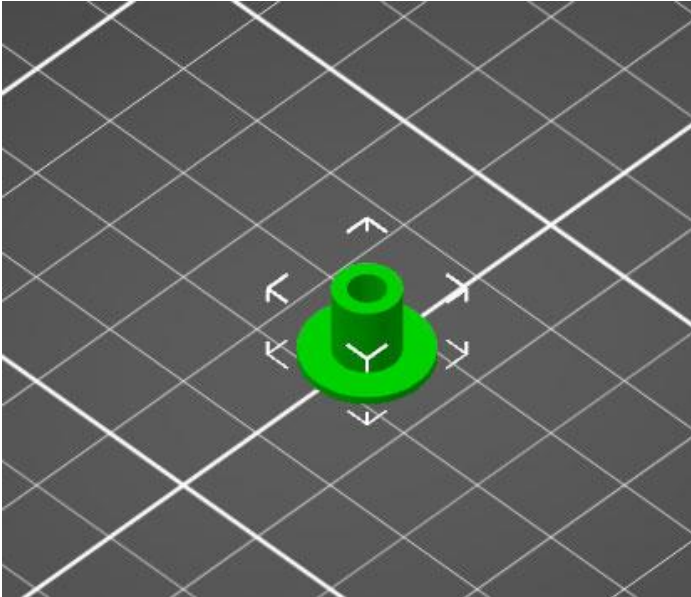

Inner boss PETG or more tough material. is not recommended,however indoor use can be okay

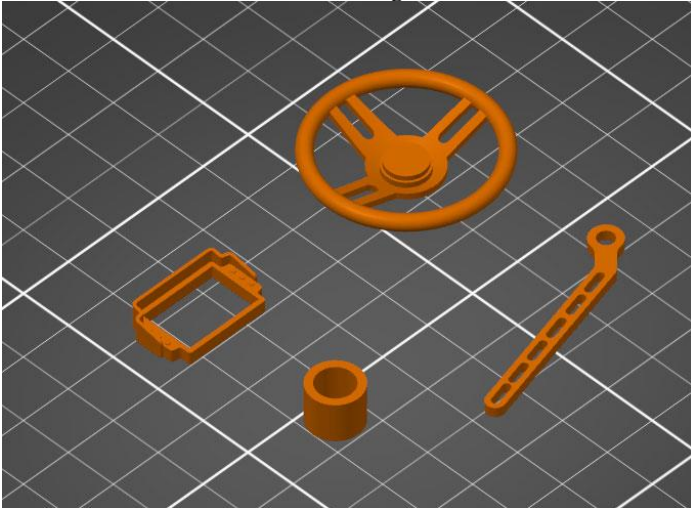

PLA is okay

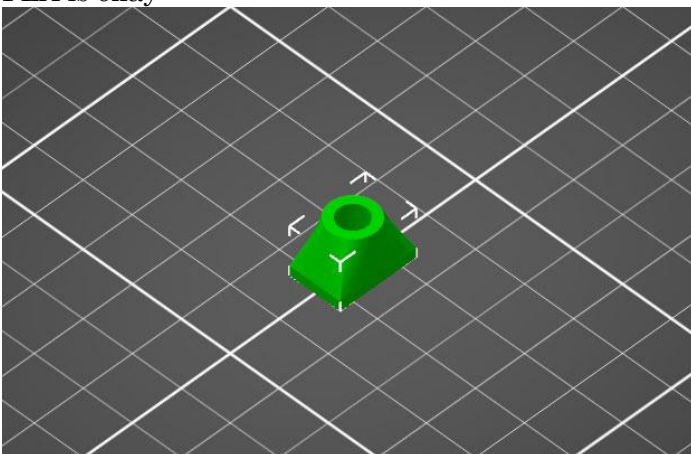

LCD display transparent/semi-transparent material.

All of parts infill rate: 20%or more.

Haltech display JPG image, Print out with sticker sheet.

What you need without this kit

1. 9gServo you can get from Amazon at a cheaper price
2. 5*2 neodymium magnet you can get from Amazon at a cheaper price
3. Silicon tube Fuel tube for IC engine, you can get hobby shop.
4. 3*6 Flathead screw x3
5. 3*6 Botton screw x3
6. Appropriate Glue for material.
7. Double side tape

Assemble manual

1,

Print out all parts with appropriate material. This kit we strongly recommend to use Colorfabb HT filament.

2, Gearholder

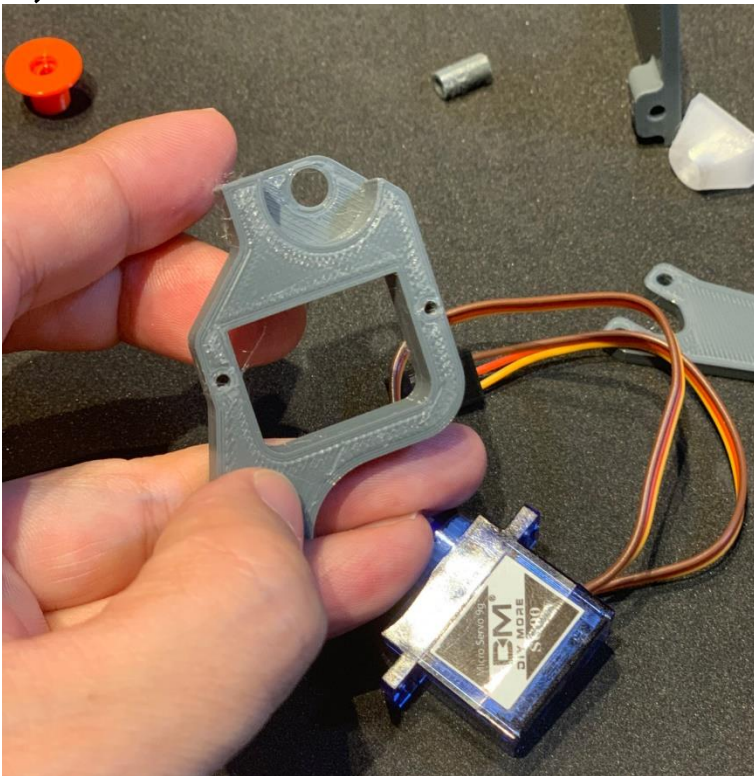

Install 9g servo on gear holder. Servo comes with self tapping screws. Use this screw and assemble.



Check the part's dimensions

3 install the gear



And set the gear with self tapping screws that come with the servo.

4 make output gear



Check output 17T gear and shaft. Gear should apply for hole side. When assembling them, apply appropriate glue.



With M3*6 Bottom screw the shaft must spin easily.

Those parts and Gear frame assemble with glue. When you assemble it, please gear's backlash and check the gears moves smoothly.

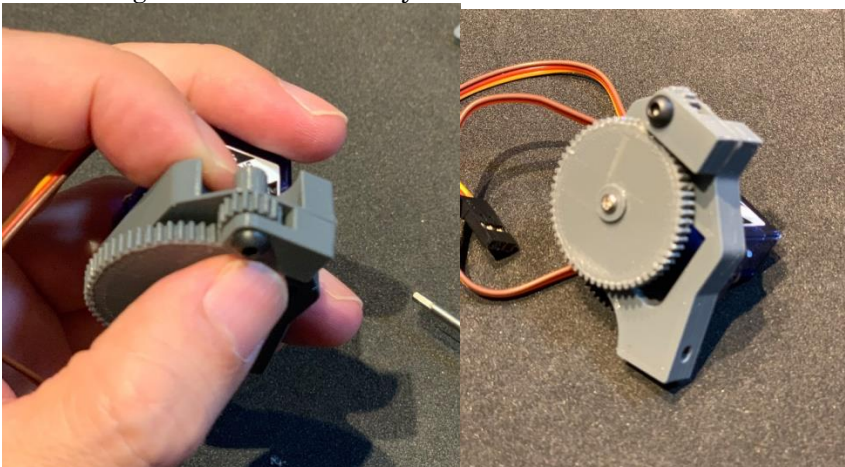

5, Assenble Steering shaft



Cut the silicon tube 22mm and connect the steering shaft.



And then insert the shaft. If the hole is tight, smoothing the hole using a 4 mm drill

6 Assemble Steering Unit

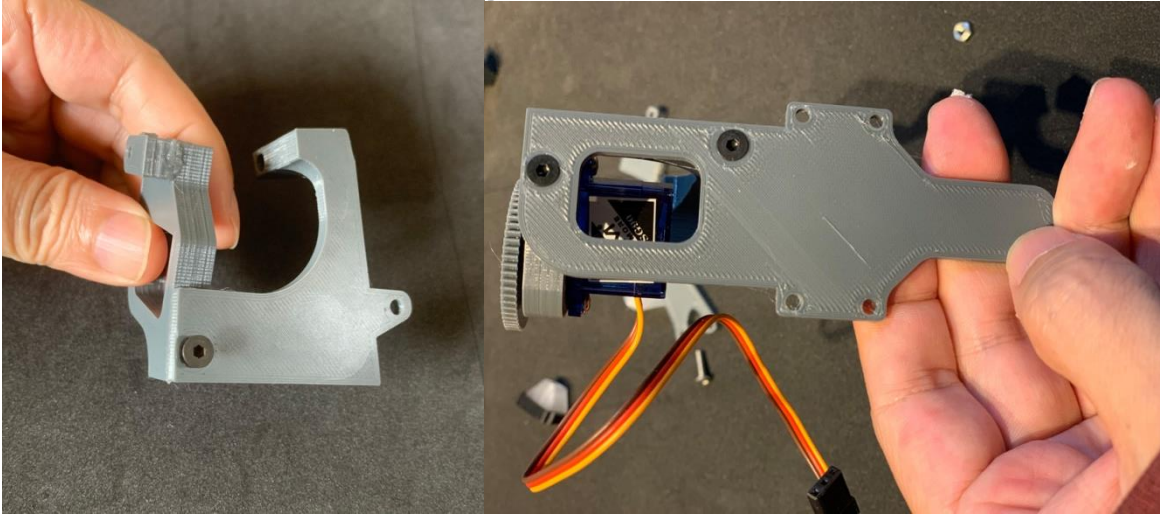

Use glue with screw will be better.

7 Steering column assembly

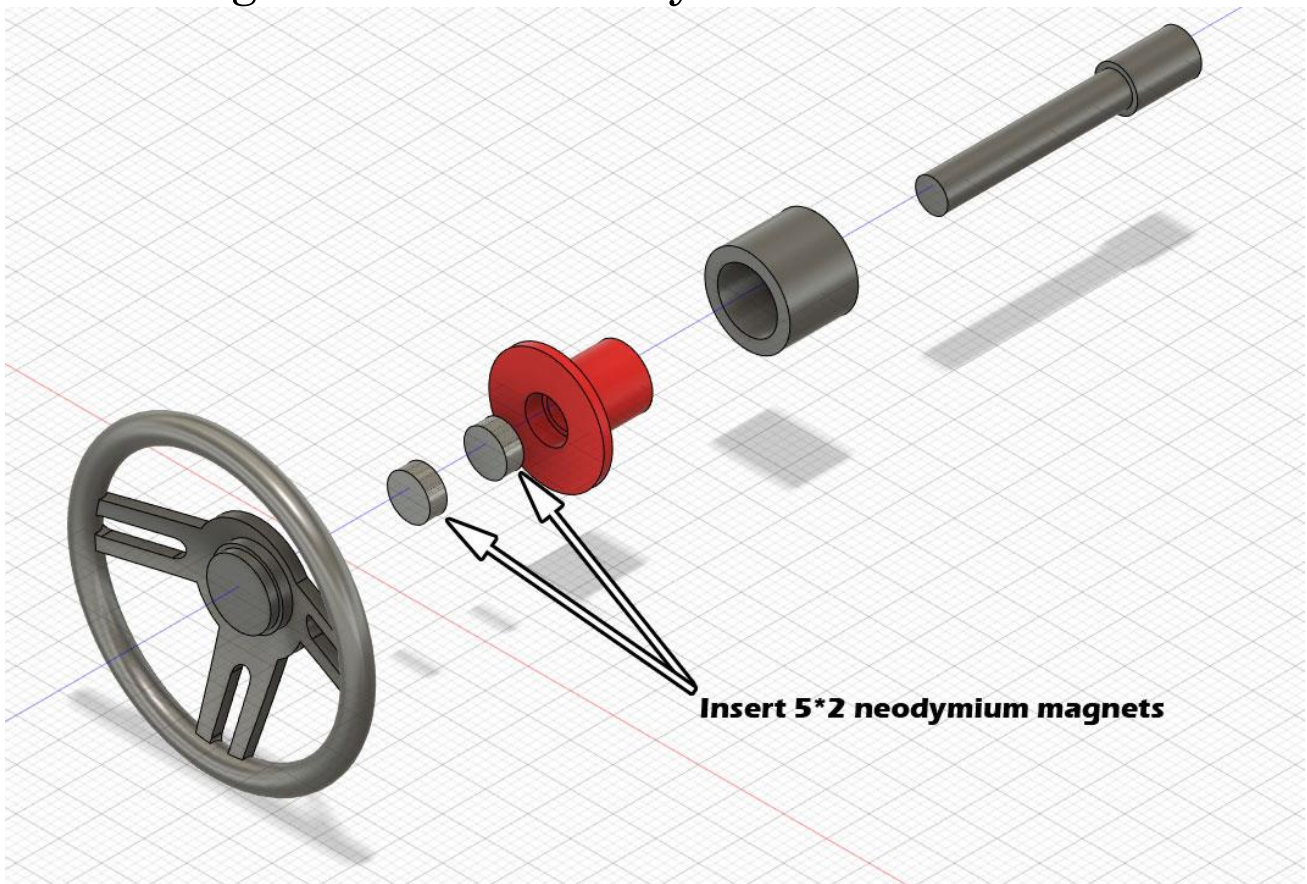

8 ChoseRHD/LHD

You can choose chassis holder sides.



This case chosen LHD

9, Attach to the chassis.

Use pinch,you adjust the mounting place, and fix with double side tape



Disclaimer

Do not use this file for commercial purposes without any permission.

This model is designed to make FDM 3Dprinter, the parts have some additive markings, however, is no problem with those parts' functions.

We use/recommend ColorfabbHT firmament

<https://colorfabb.com/colorfabb-ht-tritan>

If you have any question, please contact is via a form.

<https://www.crafthub.io/contact-us/>

Crafthub.io kay Hirano

<http://www.crafthub.io>

Instagram: @crafthub.io

Youtube: https://www.youtube.com/channel/UC5s76d53JdKf_krIeUo6MQ/videos